

BT8932E

Audio Player Microcontroller

Versions: 0.0.5
2024.12.17



Declaration

Copyright © 2023, www.bluetrum.com.

All Rights Reserved. No Unauthorized Distribution.

Bluetrum reserves the right to make changes without further notice to any products herein to improve reliability, function or design.

For further information on the technology, product and business term, please contact Bluetrum Company.

For sales or technical support, please send email to the address:

Sales: sales@bluetrum.com

Technical: project@bluetrum.com

Revision History

Date	Version	Comments	Revised by
2023-11-9	0.0.1	First draft	Leo
2023-12-8	0.0.2	Modify RAM value	Leo
2023-12-26	0.0.3	Update audio DAC parameters and audio ADC parameters	Leo
2024-04-03	0.0.4	Modify I/O drive current parameters	Leo
2024-12-17	0.0.5	Update to BT6.0	Leo

Table of Contents

TABLE OF CONTENTS	2
1 PRODUCT FEATURES	3
2 BLOCK DIAGRAM	4
3 PACKAGE DEFINITION	5
3.1 PIN ASSIGNMENT	5
3.2 PIN DESCRIPTIONS	6
4 CHARACTERISTICS	9
4.1 PMU PARAMETERS	9
4.2 IO PARAMETERS	10
4.3 AUDIO DAC PARAMETERS	11
4.4 AUDIO ADC PARAMETERS	11
4.5 BT PARAMETERS	12
4.6 CURRENT PARAMETERS	13
5 PACKAGE INFORMATION	14

1 Product Features

CPU and Flexible IO

- High performance 32bit RISC-V processor Core with DSP instruction
- RISC-V typical speed: 140MHz
- Program memory: internal 8M bit flash
- Internal 320KB RAM for data and program
- Flexible GPIO pins with Programmable pull-up and pull-down resistors
- Support GPIO wakeup or interrupt

Bluetooth Radio

- Compliant with Bluetooth V6.0 + BR + EDR + BLE specification
QDID: Q309899 (Controller)
QDID: Q304434 (Host)
- Maximum TX output power +10.5dBm;
- RX Sensitivity with -94.5dBm @2M EDR;
- Support TWS communication with balance-efficiency Power consumption;
- Support TWS Master-slave switch;

Audio Interface

- High performance stereo DAC with 104dB SNR, support differential mode and VCMBUF mode;
- High performance stereo ADC with 102dB SNR;
- Two channels MIC amplifier input;
- Support flexible audio EQ adjust;
- Support Sample rate 8, 11.025, 12, 16, 22.05, 32, 44.1, 48, 88.2,96, 176.4 and 192KHz;
- One channel stereo Analog MUX;

Applications

- Bluetooth TWS Headset;

Peripheral and Interfaces

- Support feedforward ANC (FF ANC) ;
- Support dual MIC DNN ENC noise reduction;
- Support Neural network Processing Unit (NPU);
- Support MPEG-1/2/3; AAC, SBC high quality decode;
- Support Low power Touch Key;
- Support Low power enter ear detect;
- 32-bit normal timer x 3; multi-function 32-bit timer x 3;
- WatchDog;
- Full-duplex normal UART x 3; high speed UART x 1;
- Master/Slave SPI x2;
- Master/Slave IIS x1;
- Master/Slave IIC x1;
- IR controller;
- SD Card Host controller x 1;
- Full speed USB 2.0 HOST/DEVICE controller x1;
- 10-bit SARADC x 10;
- Integrate IRTC;
- Build in PMU, such as charger/buck/LDO;

Package

- QFN32 4*4

Temperature

- Operating temperature: -40°C to +85°C;
- Storage temperature: -65°C to +150°C ;

2 Block diagram

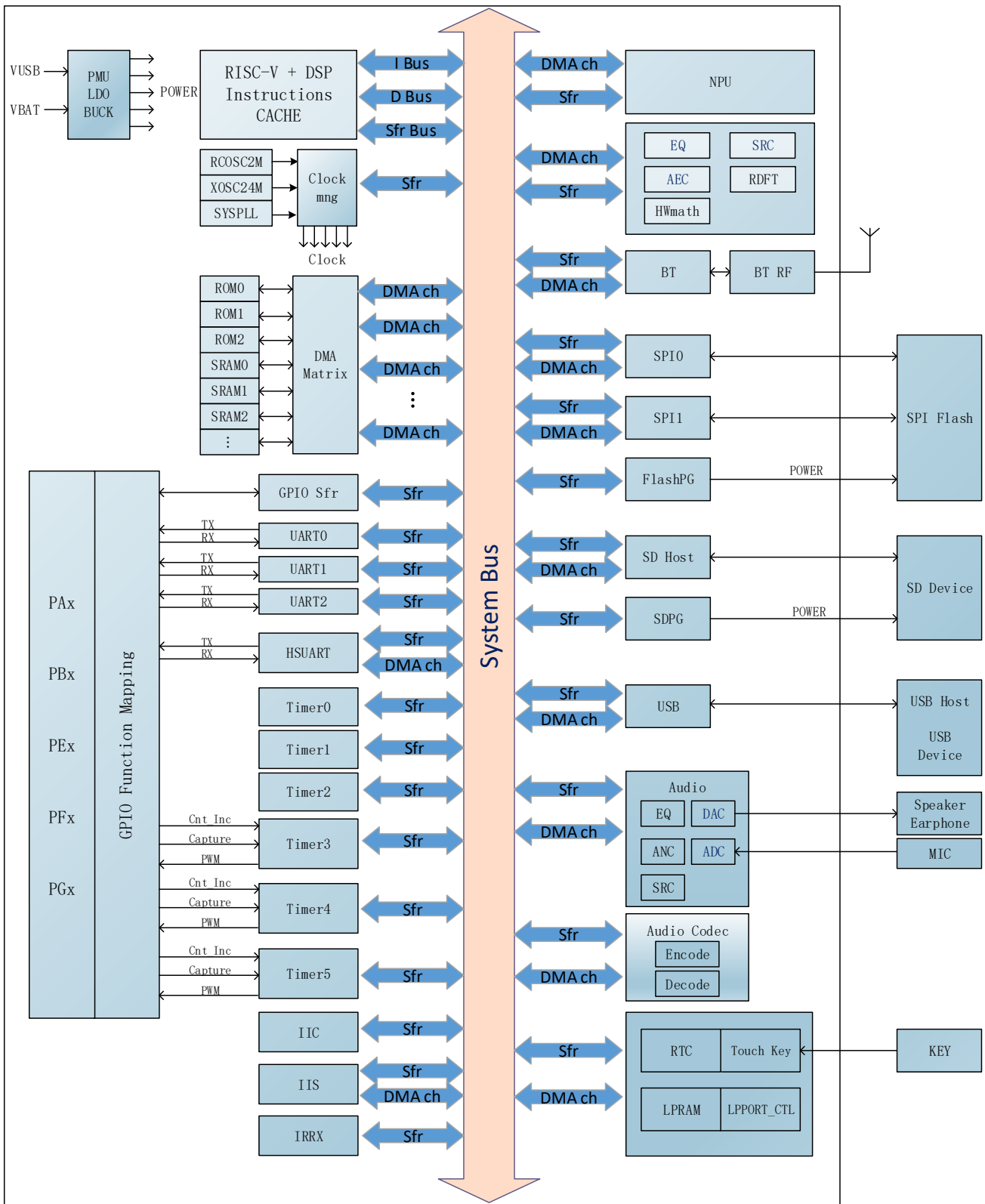

3 Package Definition

3.1 Pin Assignment

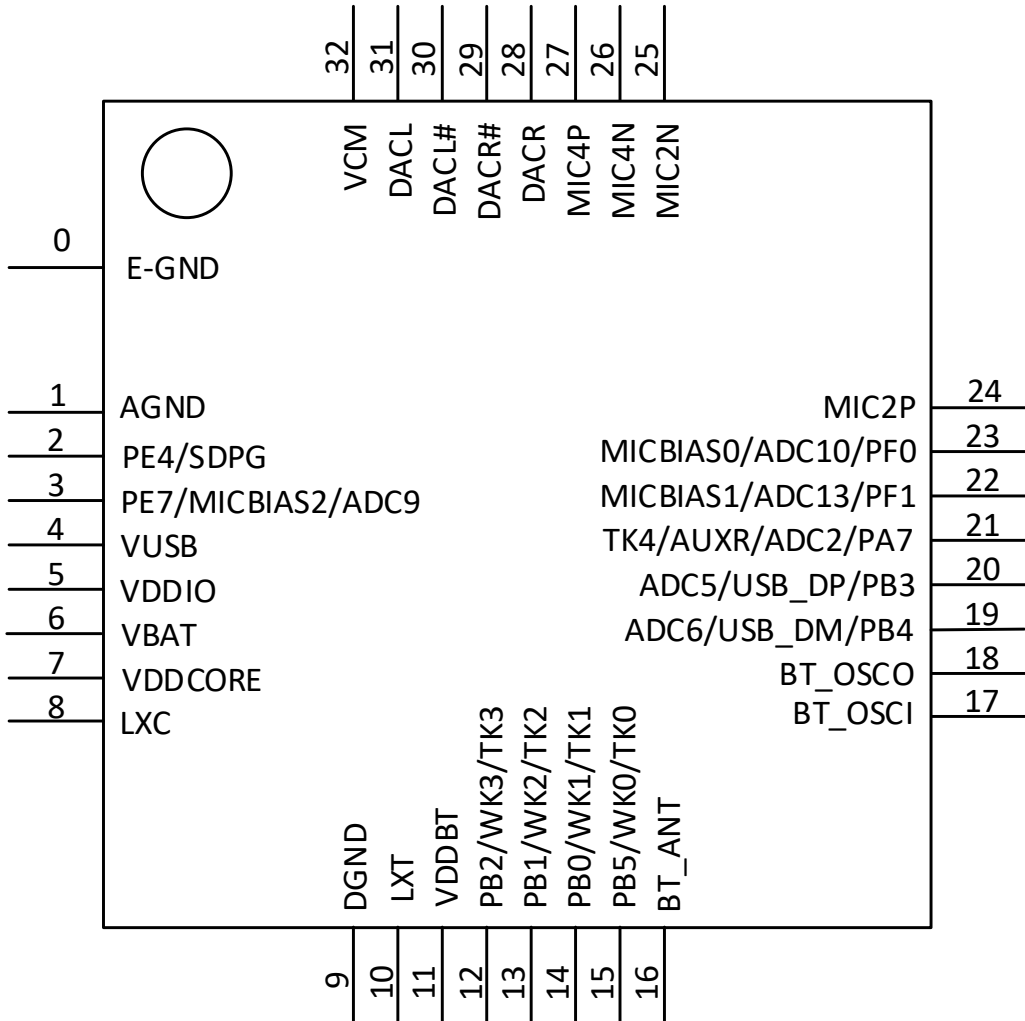

3.2 Pin Descriptions

Table 3-1 QFN32 pin description

Pin No.	Name	Type	Drive(mA)	Function
0	E-GND	GND	/	E-pad
1	AGND	GND	/	DAC Ground
2	PE4 / SDPG	I/O	8/32	SD Power Gate IISMCLK-G2 INT1-G2 PWM5-G2 PE4
3	PE7 / MICBIAS2 / ADC9	I/O	8/32	MICBIAS2-300R ADC9 AUXR0 SDDAT0-G3 SPI1DO/SPI1DATA-G4 IISDO/DAT-G2 IIC_DAT-G5 TX0-G4 TX2-G1 HSTRX-G4 INT3-G1 PWM2-G3 TMR4CAP_G1/IR_G8 PE7
4	VUSB	PWR	/	VUSB power input
5	VDDIO	PWR	/	VDDIO power output
6	VBAT	PWR	/	VBAT power input
7	VDDCORE	PWR	/	VDDCORE power
8	LXC	PWR	/	Buck inductor interface for VDDCORE
9	DGND	GND	/	Digital Ground
10	LXT	PWR	/	Buck inductor interface for BT
11	VDDBT	PWR	/	BT power
12	PB2 / WK3 / TK3	I/O	8/32	WK3 Touch3 ADC4 SDDAT0-G2 SPI1DO/SPI1DATA-G3 IISDO/DAT-G3 IIC_DAT-G3 TX0-G2 TX2-G2 HSTRX-G2 INT2-G0 PWM0-G2 PB2

13	PB1 / WK2 / TK2	I/O	8/32	WK2 Touch2 ADC3 SDCLK-G2 SPI1CLK-G3 IISLRCLK-G3 IIC_CLK-G3/G4 RX0-G2 RX2-G2 HSTRX-G7 INT1-G0 FMOSC-G4 PWM5-G1 TMR3CAP_G4/IR_G4 PB1
14	PB0 / WK1 / TK1	I/O	8/32	WK1 Touch1 ADC11 SDCMD-G2 SPI1DI-G3/SPI2W_DI01-G3 IISCLK-G3 IIC_DAT-G4 INT6-G0 FMOSC-G3 PWM4-G1 TMR3CAP_G3/IR_G3 PB0
15	PB5 / WK0 / TK0	I/O	8/32	10S Reset WK0 Touch0 ADC12 SPI1DI-G1 SPI2W_DIO1-G1 IISDI-G3 INT5-G0 PWM3-G2 PB5
16	BT_ANT	A	/	BT ANT
17	BT_OSCI	A	/	24M OSC input
18	BT_OSCO	A	/	24M OSC output
19	PB4 / USBDM / ADC6	I/O	8/32	USBDM ADC6 SDDAT0-G4/G6 SPI1DO/SPI1DATA-G1 IISMCLK-G3 IIC_DAT-G7 RX0-G3 HSTRX-G8 INT4-G0 FMOSC-G7 PWM2-G2 PB4
20	PB3 / USBDP / ADC5	I/O	8/32	USBDP ADC5 SDDAT0-G5/SDCMD-G6 SPI1CLK-G1 IISDI-G1 IIC_CLK-G7

				TX0-G3 HSTRX-G3 INT3-G0 PWM1-G2 PB3
21	PA7/ADC2/AUXR/TK4	I/O	8/32	SD Update interface ADC2 AUXR1 SDDAT0-G1 SPI1DO/SPI1DATA-G2 IISDO/DAT-G1 IIC_DAT-G1 TX0-G1 TX1-G1 HSTRX-G1 INT0-G0 PWM3-G1 PA7
22	PF1/ADC13/MICBIAS1	I/O	8/32	MICBIAS1 ADC13 IIC_DAT-G8 RX1-G2 HSTRX-G10 INT4-G1 PWM4-G3 PF1
23	PF0/ADC10/MICBIAS0	I/O	8/32	MICBIAS0 ADC10 IIC_CLK-G8 TX1-G2 HSTRX-G5 INT3-G2 PWM3-G3 TMR5CAP_G1/IR_G9 PF0
24	MIC2P	A	/	Microphone2 positive input
25	MIC2N	A	/	Microphone2 negative input
26	MIC4N	A	/	Microphone4 negative input
27	MIC4P	A	/	Microphone4 positive input
28	DACR	A	/	DAC Right Channel
29	DACR#	A	/	DAC differential R#
30	DACL#	A	/	DAC differential L#
31	DACL	A	/	DAC Left Channel
32	VCM	PWR	/	DAC VCM

Note: I/O: Digital input/output; I : Digital input; A : Analog Pin; PWR: Power Pin; GND: Ground.

4 Characteristics

4.1 PMU Parameters

Table 4-1 PMU voltage input Parameters

Sym	Characteristics	Min	Typ	Max	Unit	Conditions
VUSB	Charger Voltage input	4.6	5.0	5.5	V	
VBAT	Voltage input	3.0	3.7	4.5	V	

Table 4-2 3.3V LDO Parameters

Sym	Characteristics	Min	Typ	Max	Unit	Conditions
VDDIO	3.3V LDO voltage output	2.4	3.3	3.6	V	Light Loading condition Step 0.1v
Δ VVDDIO	Output Mismatch 1-sigma	-	17	-	mV	VDDIO=3.3v
ILOAD	Maximum output current	-	-	150	mA	@VBAT=3.6v
ISC	Short Circuit Current Limit	-	-	750	mA	@VBAT=3.8v

Table 4-3 1.25V LDO Parameters

Sym	Characteristics	Min	Typ	Max	Unit	Conditions
VDDBT/BT_AVDD	1.25V LDO voltage output	0.85	1.25	1.6	V	Light Loading condition Step 0.05v
Δ VVDDBT	Output Mismatch 1-sigma	-	9	-	mV	VDDBT=1.25v
ILOAD	Maximum output current	-	-	100	mA	@VBAT=3.0v
ISC	Short Circuit Current Limit	-	-	300	mA	@VBAT=3.8v

Table 4-4 1.1V LDO Parameters

Sym	Characteristics	Min	Typ	Max	Unit	Conditions
VDDCORE	1.1V LDO voltage output	0.7	1.1	1.475	V	Light Loading condition Step 0.025v
Δ VVDDCORE	Output Mismatch 1-sigma	-	6	-	mV	VDDCORE=1.1v
ILOAD	Maximum output current	-	-	75	mA	@VBAT=3.6v
ISC	Short Circuit Current Limit	-	-	300	mA	@VBAT=3.8v

Table 4-5 1.25V BUCK Parameters

Sym	Characteristics	Min	Typ	Max	Unit	Conditions
VDDBT	1.25V BUCK voltage output	0.85	1.25	1.6	V	Light Loading condition Step=0.05v
Δ VVDDBT	Output Mismatch 1-sigma	-	6	-	mV	VDDBT=1.25v
ILOAD	Maximum output current	-	-	360	mA	@VBAT=3.8v
ISC	Short Circuit Current Limit	-	-	360	mA	@VBAT=3.8v

Table 4-6 1.1V BUCK Parameters

Sym	Characteristics	Min	Typ	Max	Unit	Conditions
VDDCORE	1.1V BUCK voltage output	0.7	1.1	1.475	V	Light Loading condition Step=0.025v
ΔVDDCORE	Output Mismatch 1-sigma	-	6	-	mV	VDDCORE=1.1v
ILOAD	Maximum output current	-	-	360	mA	@VBAT=3.8v
ISC	Short Circuit Current Limit	-	-	360	mA	@VBAT=3.8v

4.2 IO Parameters

Table 4-6 I/O Parameters

GPIO—Electrical Characteristics							
Symbol	Description	Related GPIO	Min	Typical	Max	Units	Conditions
VIL	Low-level input voltage		-0.3		1.27	V	VDDIO=3.3V
VIH	High-level input voltage		2.03		3.6	V	VDDIO=3.3V
Driver Ability 1	Output Driver Ability 1			32		mA	VDDIO=3.3V
Driver Ability 0	Output Driver Ability 0			8		mA	VDDIO=3.3V
RPUP0	Internal pull-up resistor 0		8	10	12	KΩ	
RPUP1	Internal pull-up resistor 1		0.24	0.3	0.36	KΩ	
RPUP2	Internal pull-up resistor 2		160	200	240	KΩ	
RPDN0	Internal pull-down resistor 0		8	10	12	KΩ	
RPDN1	Internal pull-down resistor 1		0.24	0.3	0.36	KΩ	
RPDN2	Internal pull-down resistor 2		160	200	240	KΩ	

Table 4-7 Internal Resistor Characteristics

Port	General Output	High Drive	Internal Pull-Up Resistor (Ω)	Internal Pull-Down Resistor (Ω)	Comment
PA4-PA7 PB0-PB5 PE0, PE5-PE7 PF0-PF1 PG0-PG5	8mA	32mA	300/10K/200K	300/10K/200K	Internal pull-up/pull-down resistance accuracy +/-20%
PE4	8mA	32mA	10K	10K	

4.3 Audio DAC Parameters

Table 4-8 Audio DAC Normal Mode Parameters

Mode	Sym	Characteristics	Min	Typ	Max	Unit	Conditions
Differential Mode	SNR		-	104.1	-	dB	VCM cap=1uF VDDDAC cap=NC simulation with 32Ω loading Fin=1KHz
	THD+N		-	-93	-	dB	VCM cap=1uF VDDDAC cap=NC simulation with 32Ω loading Fin=1KHz
	Max Output Range		-	-2.4		dBV	32ohm Loading
VCMBUF Mode	SNR			96.2		dB	VCM cap=1uF VDDDAC cap=NC simulation with 32Ω loading Fin=1KHz
	THD+N			-77.6		dB	VCM cap=1uF VDDDAC cap=NC simulation with 32Ω loading Fin=1KHz
	Max Output Range			-8.6		dBV	32ohm Loading

Table 4-9 Audio DAC Expanded Mode Parameters

Mode	Sym	Characteristics	Min	Typ	Max	Unit	Conditions
Differential Mode	SNR		-	104	-	dB	VCM cap=1uF VDDDAC cap=NC simulation with 32Ω loading Fin=1KHz
	THD+N		-	-95	-	dB	VCM cap=1uF VDDDAC cap=NC simulation with 32Ω loading Fin=1KHz
	Output Range	Maximum output voltage	-	0		dBV	32ohm Loading@VCM=1.2V
VCMBUF Mode	SNR			102.7		dB	VCM cap=1uF VDDDAC cap=NC simulation with 32Ω loading Fin=1KHz

Mode	Sym	Characteristics	Min	Typ	Max	Unit	Conditions
	THD+N			-72.5		dB	VCM cap=1uF VDDDAC cap=NC simulation with 32Ω loading Fin=1KHz
	Output Range			-1.9		dBV	32ohm Loading@VCM=1.2V

4.4 Audio ADC Parameters

Table 4-10 Audio ADC Parameters

Mode	Sym	Characteristics	Min	Typ	Max	Unit	Conditions
ADC Mode	SNR		-	102	-	dB	VCM cap=NC VDDMIC cap=1uF tran noise simulation Input -2dBV @ Fin=1KHz
	THD+N		-	-97	-	dB	
	Input Range	Maximum input voltage	-	-2	-	dBVrms	
PGA + ADC DIFF Mode	PGA Gain		-6		42	dB	-6 / 0~42dB@step=3dB
	SNR			94		dB	VCM cap=NC VDDMIC cap=1uF diff input Input 0dBV @ Fin=1KHz PGA Gain=0dB
	THD+N			-86		dB	
	Input Range	Maximum input voltage	-	3	-	dBVrms	
PGA + ADC SINGLE Mode	PGA Gain		-6		42	dB	-6 / 0~42dB@step=3dB
	SNR			92		dB	VCM cap=NC VDDMIC cap=1uF single input Input 0dBV @ Fin=1KHz PGA Gain=0dB
	THD+N			-63		dB	
	Input Range	Maximum input voltage	-	1	-	dBVrms	

4.5 BT Parameters

Table 4-11 BT Parameters

Characteristics	Min	Typical	Max	Unit	Conditions
Transmit Power	-	9	10.5	dBm	Maximum TX power 2-DH5 packet
RMS DEVM	-	5.5	-	%	
Peak DEVM	-	15	20	%	
EDR Relative Transmit Power	-	-0.2	-	dB	
Sensitivity @ Basic Rate	-	-94.5	-	dBm	BER=0.1%, using DH5 packet
Sensitivity @ EDR	-	-94.5	-	dBm	BER=0.01%, using 2-DH5 packet

4.6 Current Parameters

Table 4-12 Current Parameters

Mode	Characteristics	Min	Typ	Max	Unit	Conditions
With DC DC Buck Mode	TX RF Current @Pout = 0dBm		TBC		mA	VBAT=3.3V
	RX RF Current @Sensitivity level		TBC		mA	
	Supply Current @Sleep with RAM retention		TBC		uA	
	Supply Current @Deep sleep		TBC		uA	
	Supply Current @Power Down		TBC		uA	
	Supply Current @Sniff		TBC		uA	500ms interval
	Supply Current @Discoverable		TBC		uA	500ms interval
W/O DC DC LDO Mode	TX RF Current @Pout = 0dBm		TBC		mA	VBAT=3.3V
	RX RF Current @Sensitivity level		TBC		mA	
	Supply Current @ Sleep with RAM retention		TBC		uA	
	Supply Current @Deep sleep		TBC		uA	
	Supply Current @Power Down		TBC		uA	
	Supply Current @Sniff		TBC		uA	500ms interval
	Supply Current @Discoverable		TBC		uA	500ms interval

5 Package Information

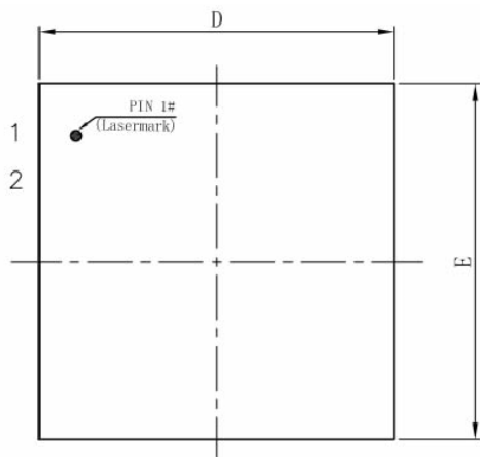

TOP VIEW

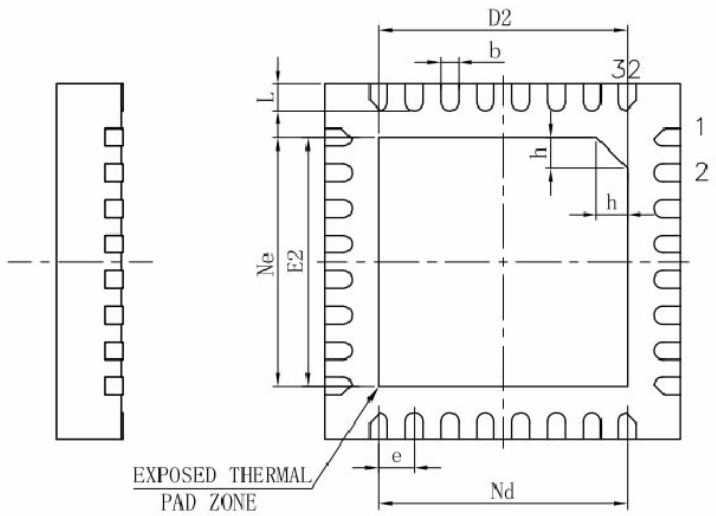

BOTTOM VIEW

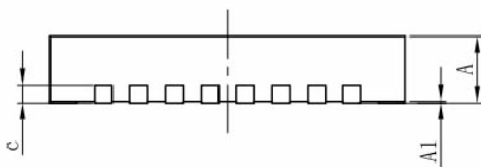

SIDE VIEW

SYMBOL	MILLIMETER		
	MIN	NOM	MAX
A	0.70	0.75	0.80
A1	0	0.02	0.05
b	0.15	0.20	0.25
c	0.18	0.20	0.25
D	3.90	4.00	4.10
D2	2.70	2.80	2.90
e	0.40BSC		
Ne	2.80BSC		
Nd	2.80BSC		
E	3.90	4.00	4.10
E2	2.70	2.80	2.90
L	0.25	0.30	0.35
h	0.30	0.35	0.40
L/F载体尺寸	122X122		



Contact us

Address : 1301-1 Building A, Zihui Square, No.4068 Qiaoxiang Road,
GaofaCommunity, Shahe Street, Nanshan District, Shenzhen, P.R.China

E-mail: info@bluetrum.com

Website: www.bluetrum.com