

AB5682C

Smart Watch Microcontroller

Versions: 0.0.3
2024.6.5



Declaration

Copyright © 2023, www.bluetrum.com.

All Rights Reserved. No Unauthorized Distribution.

Bluetrum reserves the right to make changes without further notice to any products herein to improve reliability, function or design.

For further information on the technology, product and business term, please contact Bluetrum Company.

For sales or technical support, please send email to the address:

Sales: sales@bluetrum.com

Technical: project@bluetrum.com

Revision History

Date	Version	Comments	Revised by
2023-09-28	0.0.1	First draft	Leo
2024-04-02	0.0.2	Modify I/O drive current parameters	Leo
2024-06-05	0.0.3	Update the section of Power Consumption Parameters and BT Parameters	Leo

Table of Contents

TABLE OF CONTENTS	2
1 PRODUCT FEATURES	3
2 BLOCK DIAGRAM	5
3 PACKAGE DEFINITION	6
3.1 PIN ASSIGNMENT.....	6
3.2 PIN DESCRIPTIONS.....	7
4 CHARACTERISTICS	11
4.1 PMU PARAMETERS.....	11
4.2 IO PARAMETERS	12
4.3 AUDIO DAC PARAMETERS.....	13
4.4 AUDIO ADC PARAMETERS.....	14
4.5 BT PARAMETERS	14
4.6 POWER CONSUMPTION PARAMETERS.....	15
5 PACKAGE INFORMATION	16

1 Product Features

General Description

The AB568X is a low power Wearable SOC. This SoC integrates 32-bit 140MHz RISC-V processor Core, internal NOR Flash.

The AB568X build in MIC amplifier, Sigma-Delta ADC, DAC, PMU,PLL, XOSC, image processing and Display Engine. These features make it a competitive SoC solution for application such as Smart Watch products.

CPU and Flexible IO

- High performance 32bit RISC-V processor Core with DSP instruction;
- RISC-V typical speed:140MHz;
- Program memory: internal 32Mbit Flash;
- Flexible GPIO pins with Programmable pull-up and pull-down resistors;
- Support GPIO wakeup or interrupt;

Peripheral and Interfaces

- 26M crystal oscillator circuit with on-chip loading capacitors, no external loading;
- IR Receiver;
- Display engine SPI x1; support QSPI/DSPI/SPI/3line 9bit SPI;
- Master/Slave QSPI x1 for Code SPI Flash;
- Master/Slave QSPI/DSPI/SPI x1;
- Master/Slave IIC x2;
- 10bit SARADC x11;

- Normal UART x2; High Speed UART with CTS/RTS x1;
- Full speed USB 2.0 HOST/DEVICE controller x1;
- Timers: X6. And timer5 PWM channel x6;
- Quadrature Decoder x1;
- SD Card Host controller x1;

Bluetooth Radio

- Compliant to Bluetooth 5.4 BR, EDR and BLE specification; (QDID:215269)
- Maximum TX output power +9dBm;
- RX Sensitivity with -93dBm @2M EDR;

Audio Interface

- MIC amplifier x1; High performance MONO Sigma-Delta ADC;
- High performance MONO Sigma-Delta DAC;
- Support flexible audio EQ adjust;
- Support ANS, AEC, PLC;

Graphics Accelerator

- DMA memory copy;
- Hardware Blending function;
- Hardware Rotation and Scale functions;
- SPI/DSPI/QSPI/3-wire-9bit display driver;

PMU

- Built in PMU; buck DCDC converter; capless LDOs; LDO; Power Gate;
- 300mA Li-battery charger, Support 4.35V/4.2V high voltage battery;
- VUSB for charger, support wakeup, communication, reset functions;

Temperature

- Operating temperature: -40°C to +85°C
- Storage temperature: -65°C to +150°C

Applications

- Bluetooth Smart Watch

Package

- QFN32 4*4

Key Parameters

Part Num: AB5682C

Parameter	Value
CPU	RISC-V 140MHz
RAM	TBC
Flash	SiP 32Mbit
PMU	BUCK/LDO mode + Charger
Graphics Accelerator	DMA; Rotation; Blending; Scale;
Supply Voltage	2.8~4.5V
GPIO	22
Operating Temperature	-40~+85°C
Package Size	QFN32 4*4

SoC Architecture

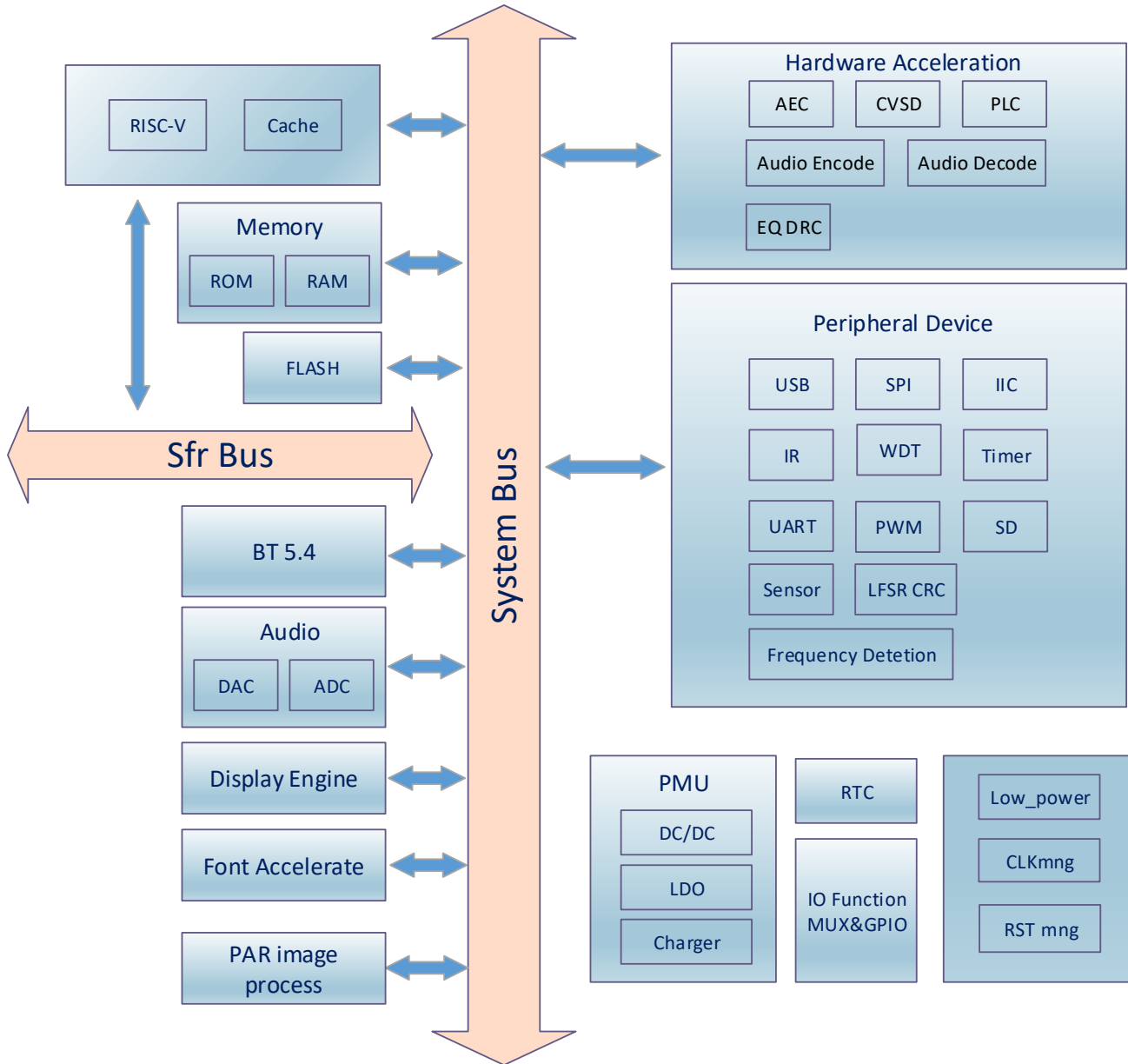

Figure 2-1 Soc Architecture Block Diagram

3 Package Definition

3.1 Pin Assignment

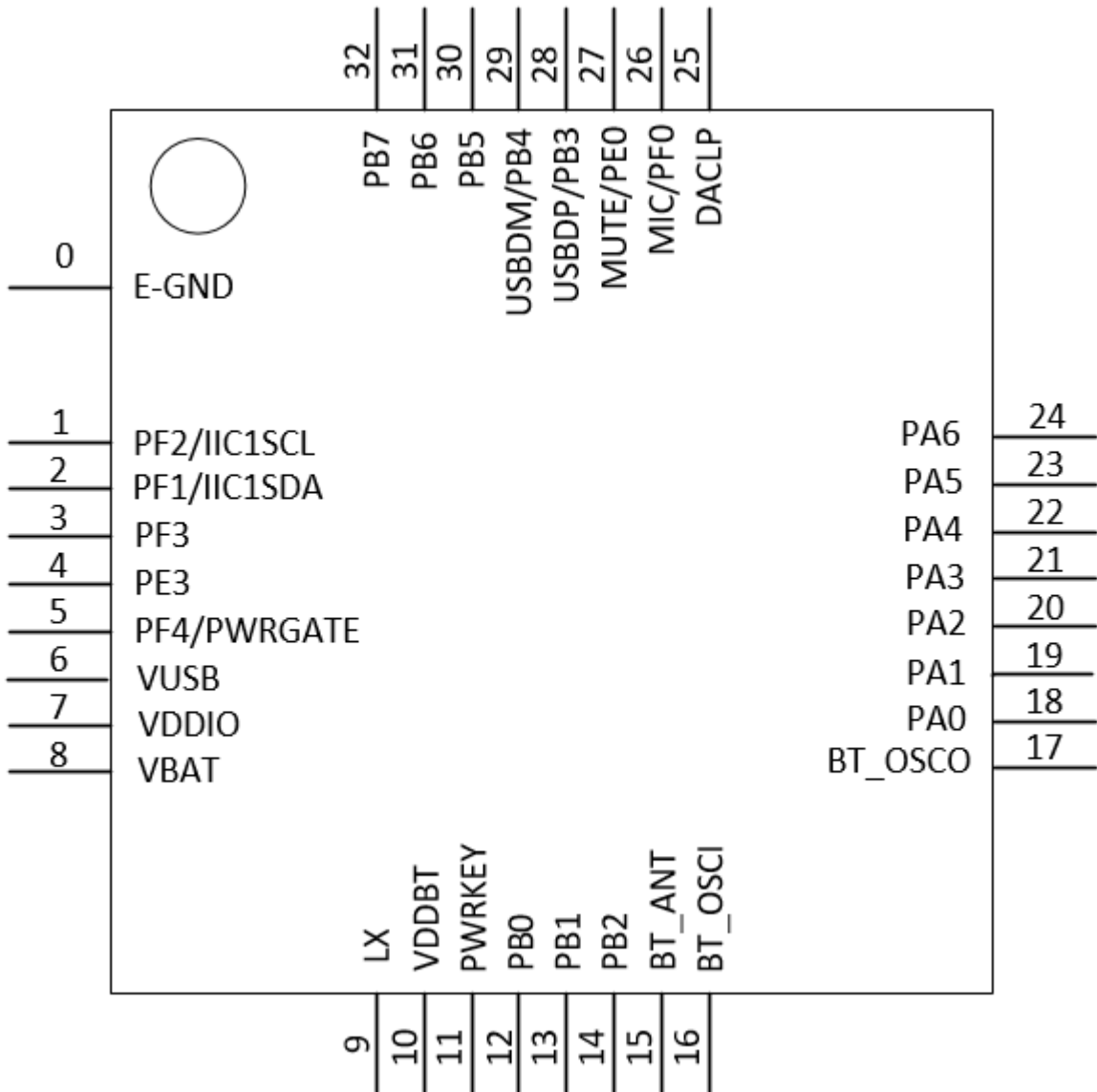

Figure 3-1 AB5682C Pin assignment for QFN32 4x4

3.2 Pin Descriptions

Table 3-2 QFN32 pin description

Pin No.	Name	Type	Drive(mA)	Function
0	E-GND	GND	/	E-pad Ground
1	PF2	I/O	8/32	Sensor Power Gate ADC9 SPI1DI-G5 IIC1SCL-G5 INT6-G2 TX1-G8 PWM2-G5 T3CPT-G9 IR-G9 PF2
2	PF1	I/O	8/32	LCD_BL ADC8 SPI1DO/SPI1DATA-G5 IIC1SDA-G5 INT3-G4 RX1-G7 PWM1-G5 PF1
3	PF3	I/O	8/32	Pedometer Input1 ADC10 SPI1CLK-G5 INT6-G3 RX1-G8 PWM3-G5 PF3
4	PE3	I/O	8/32	SDCLK-G3 INT4-G3 TX0-G4 HSTRX-G6 PWM3-G4 T3CPT-G6 IR-G6 PE3
5	PF4	I/O	8/32	3V3 Power Gate INT7-G3 CLKOUT-G5 PWM4-G5 PE4
6	VUSB	PWR	/	VUSB power input
7	VDDIO	PWR	/	VDDIO power output
8	VBAT	PWR	/	VBAT power input
9	LX	PWR	/	Buck inductor connect pin
10	VDDBT	PWR	/	BT power

11	PWRKEY	A	/	Power key input
12	PB0	I/O	8/32	ADC2 QDEC-A-G1 SDCLK-G1 SPI1DI-G2 INT2-G1 RX1-G4 PWM2-G2 T3CPT-G3 IR-G3 PB0
13	PB1	I/O	8/32	ADC3 QDEC-B-G1 SDCMD-G1 SPI1CLK-G2 IIC0SCL-G2 IIC1SCL-G2 INT3-G1 TX1-G4 HSTRX-G3 PWM3-G2 T3CPT-G4 IR-G4 PB1
14	PB2	I/O	8/32	MOTOR ADC4 SDDAT0-G1 SPI1DO/SPI1DATA-G2 IIC0SDA-G2 IIC1SDA-G2 INT4-G1 PWM4-G2 PB2
15	BT_ANT	A	/	BT ANT
16	BT_OSCI	A	/	26M OSC input
17	BT_OSCO	A	/	26M OSC output
18	PA0	I/O	8/32	LCD_D3 ADC0 SPI1DO/SPI1DATA-G1 SPI1DIO3-G6 IIC0SDA-G1 IIC1SDA-G1 INT0-G1 RX0-G2 PWM0-G1 PA0
19	PA1	I/O	8/32	LCD_D2 ADC1 SPI1CLK-G1 SPI1DIO2-G6 IIC0SCL-G1 IIC1SCL-G1 INT0-G2 TX0-G2 HSTRX-G1 PWM1-G1

				PA1
20	PA2	I/O	8/32	LCD_SDA_DO SPI1DO-G6 SPI1DIO0-G6 INT0-G3 RX0-G3 PWM2-G1 PA2
21	PA3	I/O	8/32	LCD_DC_D1 SPI1DI-G1/G6 TX0-G3 PWM3-G1 PA3
22	PA4	I/O	8/32	LCD_SCL SPI1CLK-G6 INT1-G2 RX1-G2 PWM4-G1 PA4
23	PA5	I/O	8/32	LCD_CS INT1-G3 TX1-G2 PWM5-G1 T3CPT-G1 IR-G1 PA5
24	PA6	I/O	8/32	LCD_TE-INT1-G1 RX1-G3 PWM0-G2 T3CPT-G2 IR-G2 PA6
25	DACLP	A	/	DAC Left Channel Output
26	PF0	I/O	8/32	MIC INT3-G3 TX1-G7 CLKOUT-G4 PWM0-G5 PF0
27	PE0	I/O	8	MUTE INT5-G3 TX1-G6 HSTRX-G5 CLKOUT-G3 T3CPT-G5 IR-G5 PE0
28	PB3	I/O	8/32	UART_TX ADC5 USBDP IIC0SDA-G3 IIC1SDA-G3 INT2-G2 TX0-G1

				HSTRX-G4 CLKOUT-G1 PWM5-G2 PB3
29	PB4	I/O	8/32	CTP_INT- INT5-G1 ADC6 USBDM IIC0SCL-G3 IIC1SCL-G3 RX0-G1 CLKOUT-G2 PWM0-G3 PB4
30	PB5	I/O	8/32	CTP_SDA SDDAT0-G2 SPI1DO/SPI1DATA-G3 IIC1SDA-G4 INT2-G3 PWM1-G3 PB5
31	PB6	I/O	8/32	CTP_SCL SDCMD-G2 SPI1DI-G3 IIC1SCL-G4 INT2-G4 RX1-G5 RTS PWM2-G3 PB6
32	PB7	I/O	8/32	Pedometer Input2 CTP_RST ADC7 SDCLK-G2 SPI1CLK-G3 INT4-G2 TX1-G5 CTS PWM3-G3 PB7

Note: I/O: Digital input/output; I : Digital input; A : Analog Pin; PWR: Power Pin; GND: Ground.

4 Characteristics

4.1 PMU Parameters

Table 4-1 PMU voltage input Parameters

Sym	Characteristics	Min	Typ	Max	Unit	Conditions
VUSB	Charger Voltage input	4.6	5.0	5.5	V	
VBAT	Voltage input	2.8	3.7	4.5	V	

Table 4-2 3.3V LDO Parameters

Sym	Characteristics	Min	Typ	Max	Unit	Conditions
VDDIO	3.3V LDO voltage output	2.4	3.3	3.6	V	Light Loading condition Step 0.1v
Δ VVDDIO	Output Mismatch 1-sigma	-	17	-	mV	VDDIO=3.3v
ILOAD	Maximum output current	-	-	150	mA	@VBAT=3.6v
ISC	Short Circuit Current Limit	-	-	750	mA	@VBAT=3.8v

Table 4-3 1.25V LDO Parameters

Sym	Characteristics	Min	Typ	Max	Unit	Conditions
VDDBT/BT_AVDD	1.25V LDO voltage output	0.85	1.25	1.6	V	Light Loading condition Step 0.05v
Δ VVDDBT	Output Mismatch 1-sigma	-	9	-	mV	VDDBT=1.25v
ILOAD	Maximum output current	-	-	100	mA	@VBAT=3.0v
ISC	Short Circuit Current Limit	-	-	300	mA	@VBAT=3.8v

Table 4-4 1.1V LDO Parameters

Sym	Characteristics	Min	Typ	Max	Unit	Conditions
VDDCORE	1.1V LDO voltage output	0.7	1.1	1.475	V	Light Loading condition Step 0.025v
Δ VVDDCORE	Output Mismatch 1-sigma	-	6	-	mV	VDDCORE=1.1v
ILOAD	Maximum output current	-	-	75	mA	@VBAT=3.6v
ISC	Short Circuit Current Limit	-	-	300	mA	@VBAT=3.8v

Table 4-5 1.25V BUCK Parameters

Sym	Characteristics	Min	Typ	Max	Unit	Conditions
VDDBT	1.25V BUCK voltage output	0.85	1.25	1.6	V	Light Loading condition Step=0.05v
Δ VVDDBT	Output Mismatch 1-sigma	-	6	-	mV	VDDBT=1.25v
ILOAD	Maximum output current	-	-	360	mA	@VBAT=3.8v
ISC	Short Circuit Current Limit	-	-	360	mA	@VBAT=3.8v

Table 4-6 CHARGER Parameters

Sym	Characteristics	Min	Typ	Max	Unit	Conditions
VUSB	Charger Voltage input	3	5	5.5	V	
VBAT	Constant Voltage output	4.2	4.2	4.45	V	@VUSB=5V VBAT=4.2/4.35/4.4/4.45V
ICH	Constant Current output	5	-	320	mA	@VBAT<4.15V Step=5mA
IEND	Current threshold for Stop Charging	2.5	-	37.5	mA	@VUSB=5V

4.2 IO Parameters

Table 4-7 I/O Parameters

GPIO—Electrical Characteristics							
Symbol	Description	Related GPIO	Min	Typical	Max	Units	Conditions
VIL	Low-level input voltage		-0.3		1.27	V	VDDIO=3.3V
VIH	High-level input voltage		2.03		3.6	V	VDDIO=3.3V
Driver Ability 1	Output Driver Ability 1			24		mA	VDDIO=3.3V
Driver Ability 0	Output Driver Ability 0			6		mA	VDDIO=3.3V
RPUP0	Internal pull-up resistor 0		8	10	12	K Ω	
RPUP1	Internal pull-up resistor 1		0.24	0.3	0.36	K Ω	
RPUP2	Internal pull-up resistor 2		160	200	240	K Ω	
RPDN0	Internal pull-down resistor 0		8	10	12	K Ω	
RPDN1	Internal pull-down resistor 1		0.24	0.3	0.36	K Ω	
RPDN2	Internal pull-down resistor 2		160	200	240	K Ω	

Table 4-8 Internal Resistor Characteristics

Port	General Output (mA)	High Drive (mA)	Internal Pull-Up Resistor (Ω)	Internal Pull-Down Resistor (Ω)	Comment
PA0-PA7 PB0-PB7 PE1-PE7 PF0-PF3, PF5 PG0-PG5	8	32	300/10K/200K	300/10K/200K	Internal pull-up/pull-down resistance accuracy +/-20%
PF4	8	32	10K	10K	
PE0 (High Voltage IO)	8	-	10K	10K	

4.3 Audio DAC Parameters

Table 4-9 Audio DAC Parameters

Mode	Sym	Characteristics	Min	Typ	Max	Unit	Conditions
Differential Mode	SNR		-	TBC	-	dB	VCM cap=NC VDDDAC cap=NC without loading Fin=1KHz
	THD+N		-	TBC	-	dB	VCM cap=NC VDDDAC cap=NC without loading Fin=1KHz
	max Output Range		-	4.8		dBV	without Loading
single Mode	SNR			TBC		dB	VCM cap=NC VDDDAC cap=NC without loading Fin=1KHz
	THD+N			TBC		dB	VCM cap=NC VDDDAC cap=NC without loading Fin=1KHz
	max Output Range			-1.176		dBV	without Loading

4.4 Audio ADC Parameters

Table 4-10 Audio ADC Parameters

Mode	Sym	Characteristics	Min	Typ	Max	Unit	Conditions
ADC Mode	SNR		-	94	-	dB	VCM cap=NC Input -2dBV @ Fin=1KHz
	THD+N		-	-90	-	dB	
	Input Range	Maximum input voltage	-	-2	-	dBVrms	
external-RC PGA + ADC Mode	PGA Gain		-6		42	dB	-6 / 0~42dB@step=3dB
	SNR			93		dB	VCM cap=NC Input -2dBV @ Fin=1KHz PGA Gain=0dB
	THD+N			-72		dB	
	Input Range	Maximum input voltage	-	-2	-	dBVrms	
internal-RC PGA + ADC Mode	PGA Gain		-6		42	dB	-6 / 0~42dB@step=3dB
	SNR			89		dB	VCM cap=NC Input -2dBV @ Fin=1KHz PGA Gain=0dB
	THD+N			-70		dB	
	Input Range	Maximum input voltage	-	-2	-	dBVrms	

4.5 BT Parameters

Table 4-11 BT Parameters

Characteristics	Min	Typical	Max	Unit	Conditions
Transmit Power	-	-	9	dBm	
RMS DEVM	-	5.5	-	%	Maximum TX power 2-DH5 packet
Peak DEVM	-	15	20	%	
EDR Relative Transmit Power	-	-0.2	-	dB	
Sensitivity @ Basic Rate	-	-90	-	dBm	BER=0.1%, using DH5 packet
Sensitivity @ EDR	-	-93	-	dBm	BER=0.01%, using 2-DH5 packet

4.6 Power Consumption Parameters

Table 4-12 Power Consumption Parameters

Mode	Characteristics	Min	Typ	Max	Unit	Conditions
With DC DC Buck Mode	Power off @ RTC shutdown		5		uA	VBAT=4.0V VDDBT=1.45V
	Power off @ RTC keep running		10		uA	
	Sleep mode		0.228		mA	
	Deep sleep mode		20		uA	
	BLE hold connection		0.143		mA	
	BR hold connection		0.28		mA	
	BR and BLE hold connection		0.202		mA	
W/O DC DC LDO Mode	Power off @ RTC shutdown		5		uA	VBAT=4.0V VDDBT=1.45V
	Power off @ RTC keep running		10		uA	
	Sleep mode		0.319		mA	
	Deep sleep mode		20		uA	
	BLE hold connection		0.185		mA	
	BR hold connection		0.409		mA	
	BR and BLE hold connection		0.304		mA	

5 Package Information

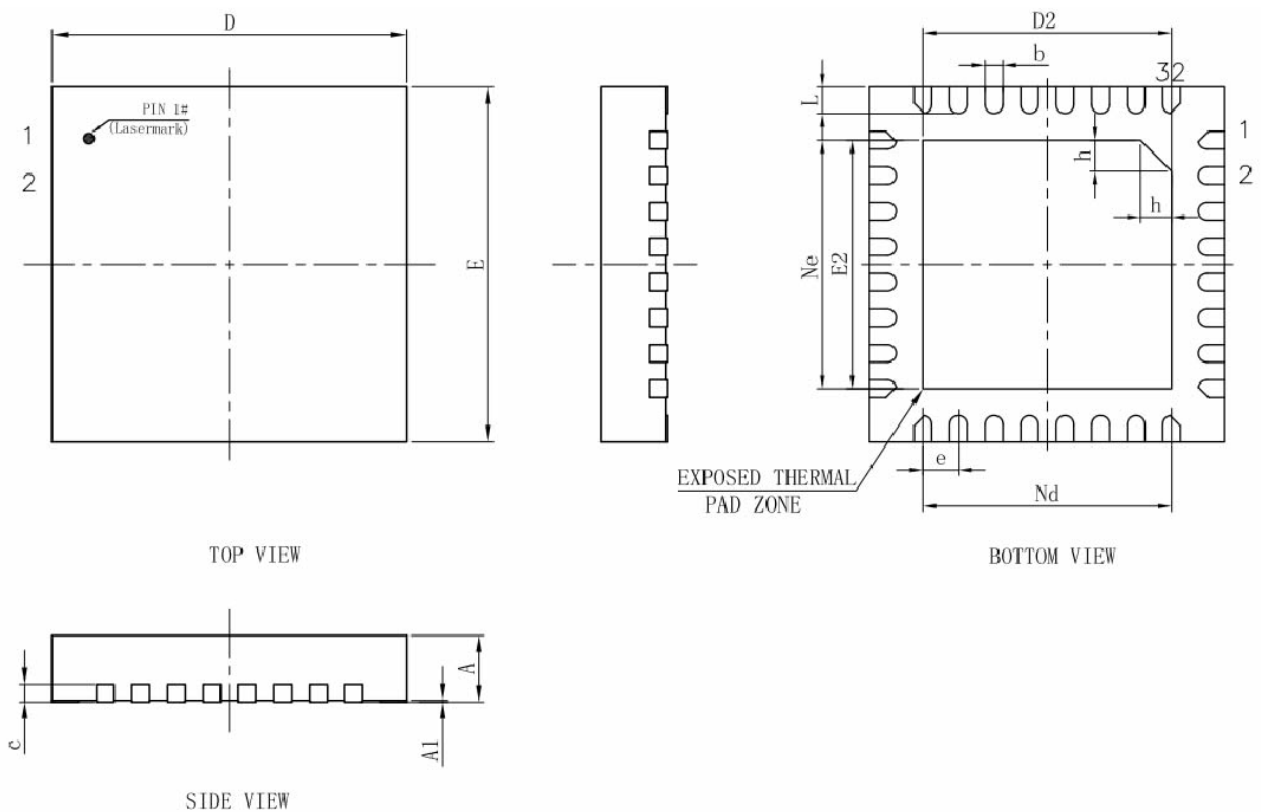

SYMBOL	MILLIMETER		
	MIN	NOM	MAX
A	0.70	0.75	0.80
A1	0	0.02	0.05
b	0.15	0.20	0.25
c	0.18	0.20	0.25
D	3.90	4.00	4.10
D2	2.70	2.80	2.90
e	0.40BSC		
Ne	2.80BSC		
Nd	2.80BSC		
E	3.90	4.00	4.10
E2	2.70	2.80	2.90
L	0.25	0.30	0.35
h	0.30	0.35	0.40
L/F载体尺寸	122X122		



Contact us

Address : 1301-1 Building A, Zihui Square, No.4068 Qiaoxiang Road,
GaofaCommunity, Shahe Street, Nanshan District, Shenzhen, P.R.China

E-mail: info@bluetrum.com

Website: www.bluetrum.com